

KOBAN



EN 60730-1:2011
EN 60730-2-9:2010
EN 61000-3-2:2006/A2:2009
EN 61000-3-3:2008
EN 55014-1:2006/A2:2011



CHARACTERISTICS

Temperature range	0-60°C
KT 60NC (normally closed)	When the temperature reaches the set value, open circuit
Switch temperature difference	7K(±4K tolerance)
Sensor element	Thermostatic bimetal
Contact type	Snap-action
Contact resistance	<10m ohm(Incidental connection line)
Service life	>100,000 cycles
Max. switching capacity	250VAC,10(2)A120VAC,15(2)A30WDC at 24VDC to 72VDC
Connection	2-pole terminal, clamping torque 0.5Nm max.: rigid wire 2.5mm ² ,stranded wire (with wire end ferrule) 1.5mm ²
Installation	35mm DIN Installation guide
Weight	40g
Fitting position	Variable
Operating/Storage temperature	-20°C to +80°C
Protection degree	IP20

THERMOSTAT KT 60NC

DIMENSIONS (mm)

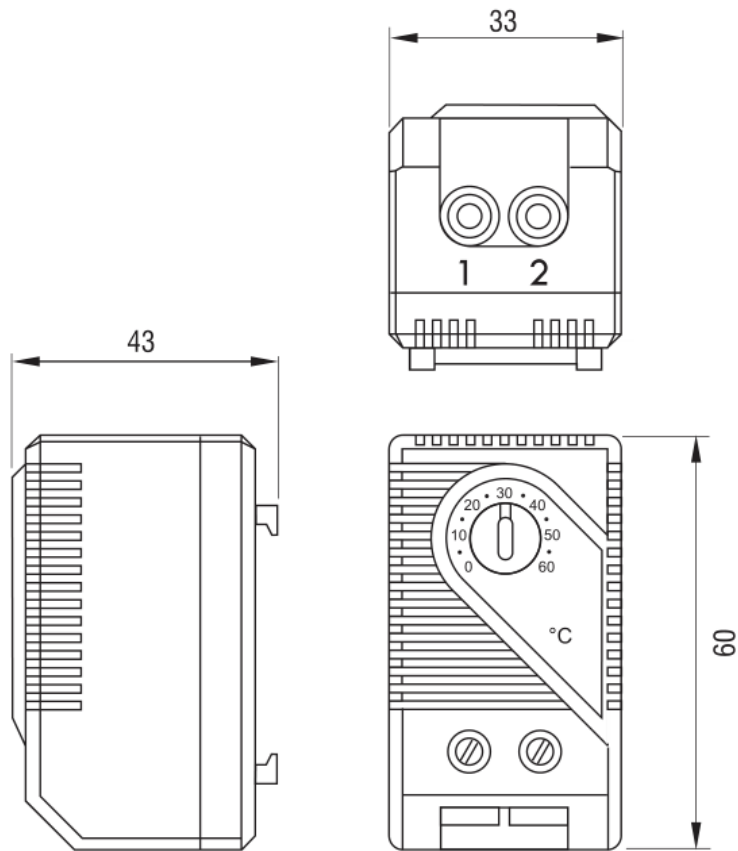

CONNECTION

Thermostat

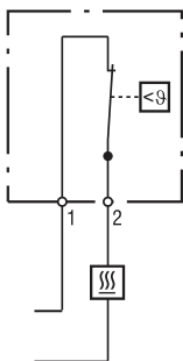

Thermostat

Heater

